



CSA - B125
ASME - A112.18.1
NSF - 61-9



PATENT NUMBERS
U.S. 5,505,227, 6,254,057, 6,382,585
Canadian 2,109,684
European 0654628
International & Other Patents Pending

SERVICE INSTRUCTIONS & PARTS LIST (ALL MODELS)

TROUBLE SHOOTING

If the faucet drips:

First determine which valve is at fault, one of the valve blocks or the pilot/actuator valve, by shutting off, in turn, with the faucet handle(s) the cold and hot water. If the dripping stops the corresponding valve block requires service, go to the valve block service procedure. If the faucet did not stop dripping, pinch off the yellow tube between the pilot/actuator valve and first valve block with a pair of needle nose pliers (*pinch closed only, DO NOT CRUSH*). If the dripping stops replace the pilot/actuator valve.

The water is very slow to shutoff or will not shutoff:

Turn off the hot and cold water supplies. Disconnect a green tube from one of the valve block barbs by prying back the sleeve and splitting the tube with a sharp knife (*DO NOT overstress the barb it may break*). Open the cold water supply shutoff partially while holding a small container under the appropriate green tube or barb fitting to catch the water. A strong steady stream should result. Using the same procedure test the flow from the hot valve block. If there is little or no flow go to the valve block service procedure. If the flow is good from the green tube connections, on both valve blocks, reconnect the green tube and disconnect the blue tube coming from the pilot/actuator valve at the valve block. Again using the same procedure, test the water flow coming from the blue tube. If there is little or no flow replace the pilot/actuator valve.

The water is very slow to turn on or will not turn on:

First verify pedal top is making solid contact with the pilot/actuator valve by removing the pedal top and operating the valve by hand. Next verify there is good flow in the blue tube from the pilot/actuator valve using the same procedure as in the above situation. If there is good flow reconnect the blue tube and disconnect the yellow tube coming from the pilot/actuator valve. With the water supplies turned on press the pilot/actuator valve while observing the water flow coming from the yellow tube. If there is a short burst of water go to the valve block service procedure. If there is none or just a few drops of water, replace the pilot/actuator valve.

Noise from valve blocks while the water is running:

Turn off the cold and hot water alternately at the faucet to determine which valve block is the source of the noise. The corresponding valve block may have excessive debris trapped under its filter-screen and requires service. See the valve block service procedure.

Valve Block Service Procedure:

Turn off the water supply(s) and disassemble the valve block by removing the four hex screws, take care not to lose the spring (*see the illustrated breakdown*). Remove the diaphragm and the filter-screen, clean all the ports in the body and manifold with vinegar or a commercial water deposit cleaner while paying particular attention to the small passages. Inspect the filter-screen and diaphragm and clean or replace as required (*note: the filter-screen is a dual purpose part which functions both as a coarse screen for the main water flow and is a porous plastic with 25 micron filtration to protect the control circuits*). Reassemble the valve block as per the illustrated breakdown and pay particular attention to the alignment of the body diaphragm and manifold. Take care not to crush the duck bill check valves on the diaphragm. Tighten the screws in an alternating crossing pattern. (*hint: if the valve block is mounted use a little Vaseline or silicone grease to hold the spring in place*).

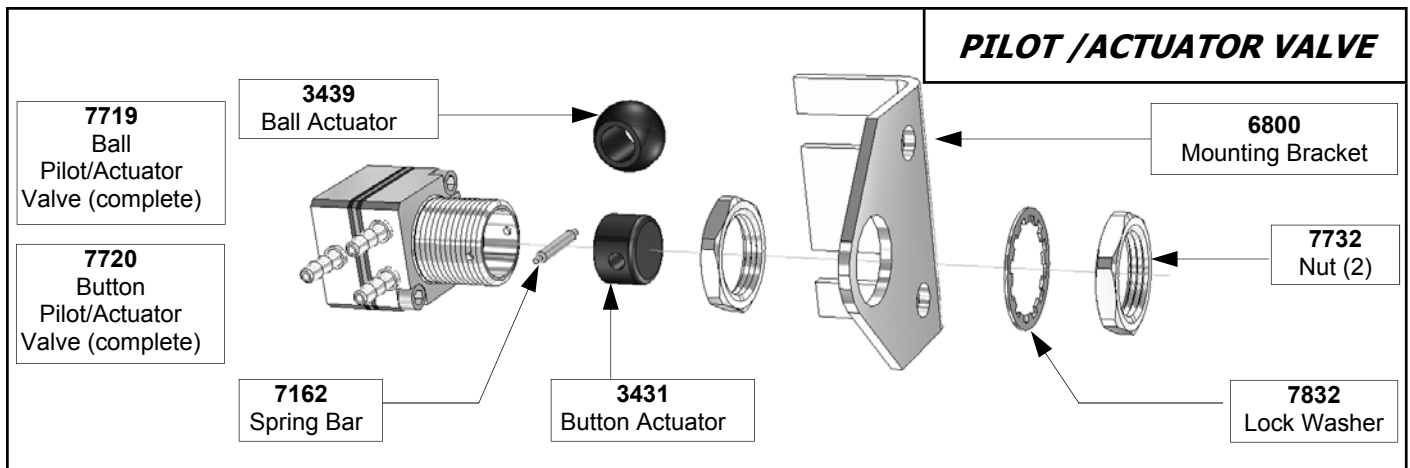
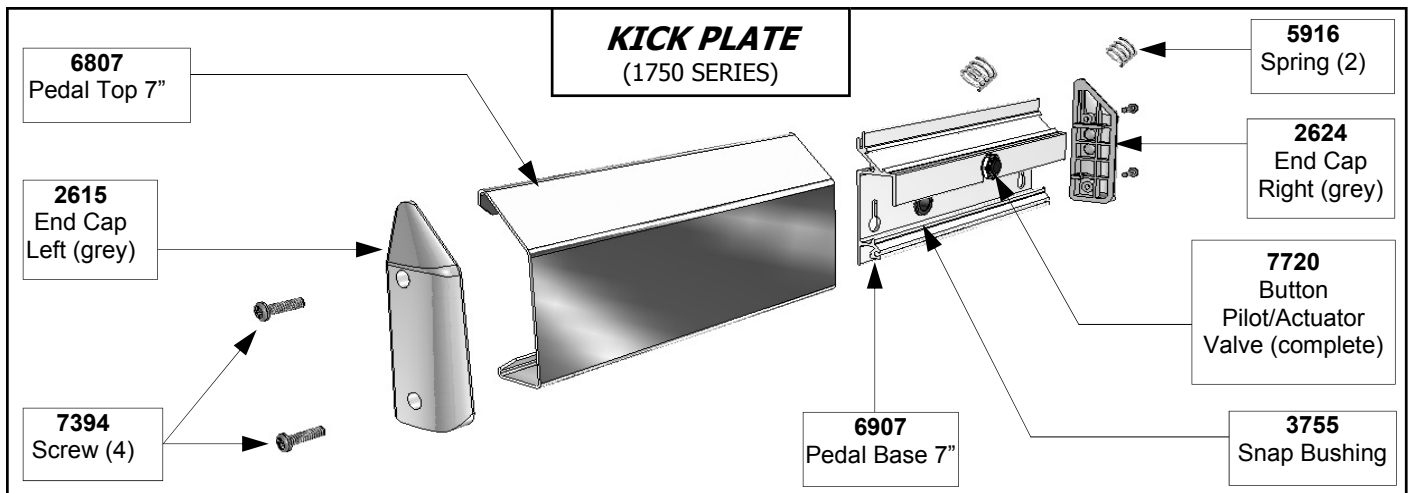
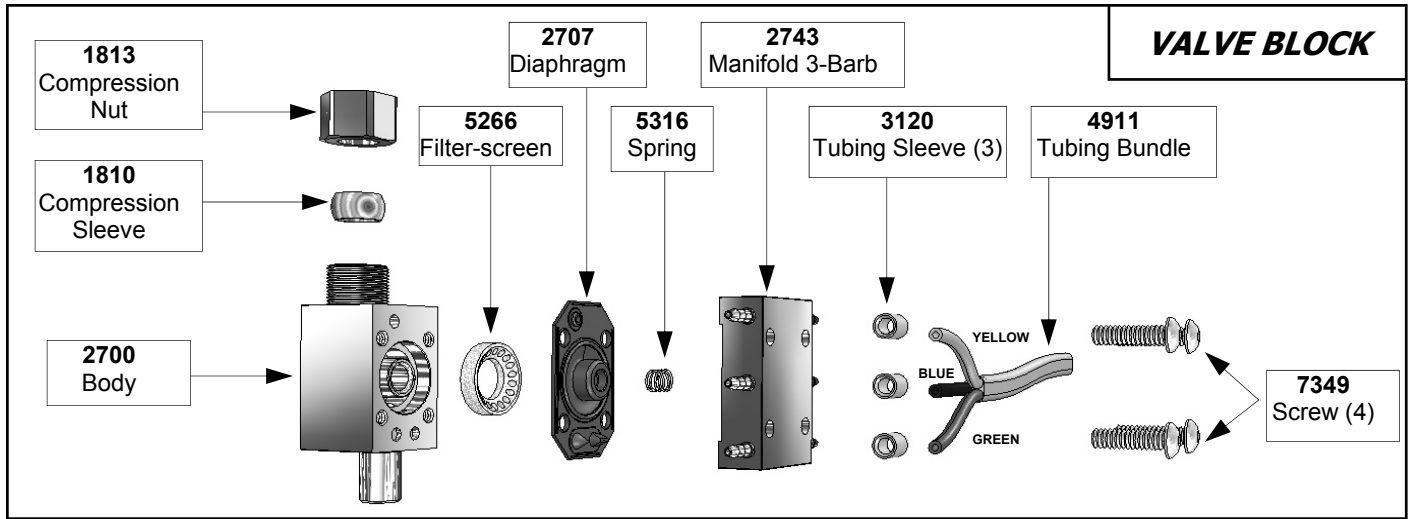

EURO FOOT ACTIVATION
(1770 SERIES)

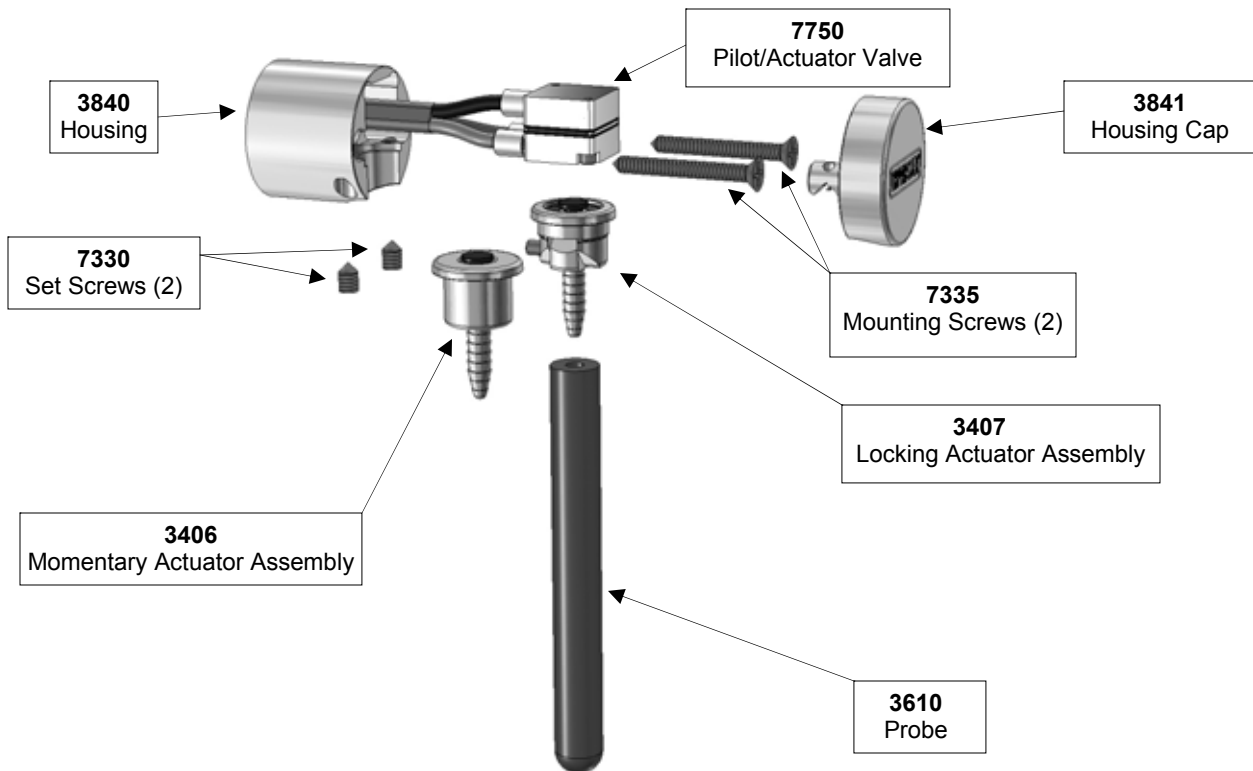

SERVICE KIT

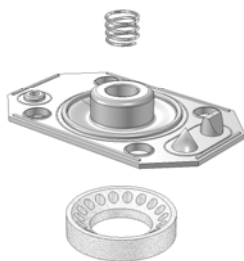

7100
Valve Block
Service Kit

FOOT PEDAL
(1760 SERIES)

