



# SUBMITTAL

PATENT NUMBERS  
 U.S. 5,505,227, 6,254,057, 6,382,585  
 Canadian 2,109,684  
 European 0654628  
 International & Other Patents Pending

## Hands Free Faucet Controllers

applies to Model 1786

### FLOOR ACTIVATOR DISC

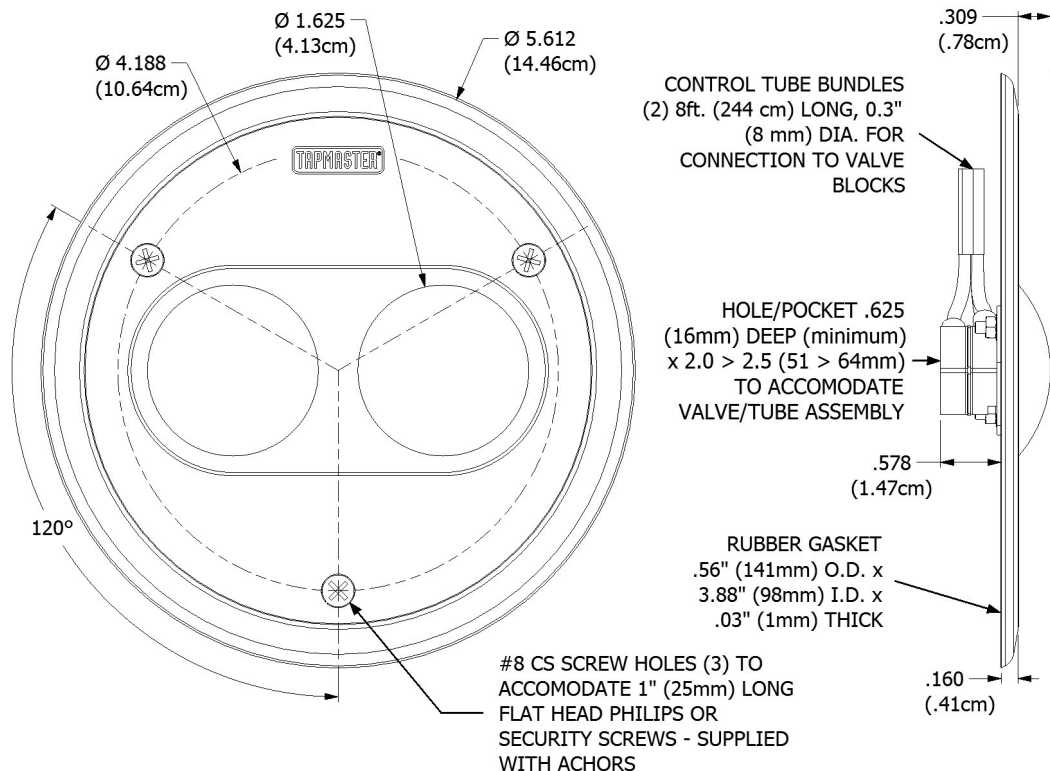

#### SPECIFICATIONS

**Construction**  
 Stainless Steel, 304 grade or better, three piece laminated/bonded with electro-polished top cover, polyurethane buttons. Mop rated

**Mounting**  
 Rubber gasket. Caulking is recommended. Three #8 x 1" (25mm) Stainless Steel flat-head screws - phillips or security type with plastic anchors provided.

**Activation**  
 Step on force requirement: Approximately 10lbs (4.5 Kilograms)  
 Motion: Approximately 0.03" (0.07 mm)

### INLINE VALVE BLOCKS

Note: single valve block for models 1740 & 1742

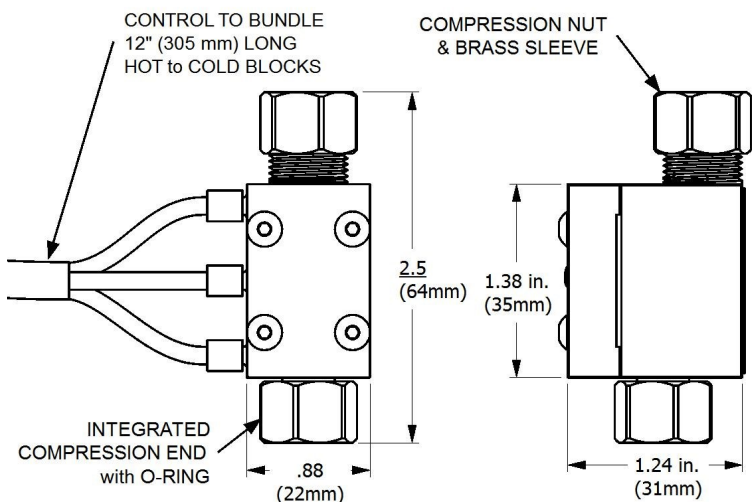

#### SPECIFICATIONS

**Pressure:** operating: 0 to 125 psi (862 kpa) max at 140°F (60°C)  
 static burst: 700 psi (4,830 kpa) at 72°F (22°C)

**Flow:** hot & cold blocks combined:  
 7.2 gpm @ 60 psi (27 l/m @ 4 bar)

**Construction:** body: chrome plated brass  
 seals: high temperature silicone  
 filter and screening: polyethylene

**Filtration:** control circuit: 25 micron  
 main port: greater than .060" (1.5 mm)

Tapmaster Incorporated  
 3-1470 28th Street NE  
 Calgary, AB Canada  
 T2A 7W6



CSA-B125.1-18  
 ASME A112.18.1-2018  
 NFS/ANSI 61-2016  
 NSF/ANSI 372-2016  
 Rev. 4.0



PH: 800-791-8117  
 FAX: 403-275-5928  
 Web: www.tapmaster.ca  
 E-mail: info@tapmaster.ca